

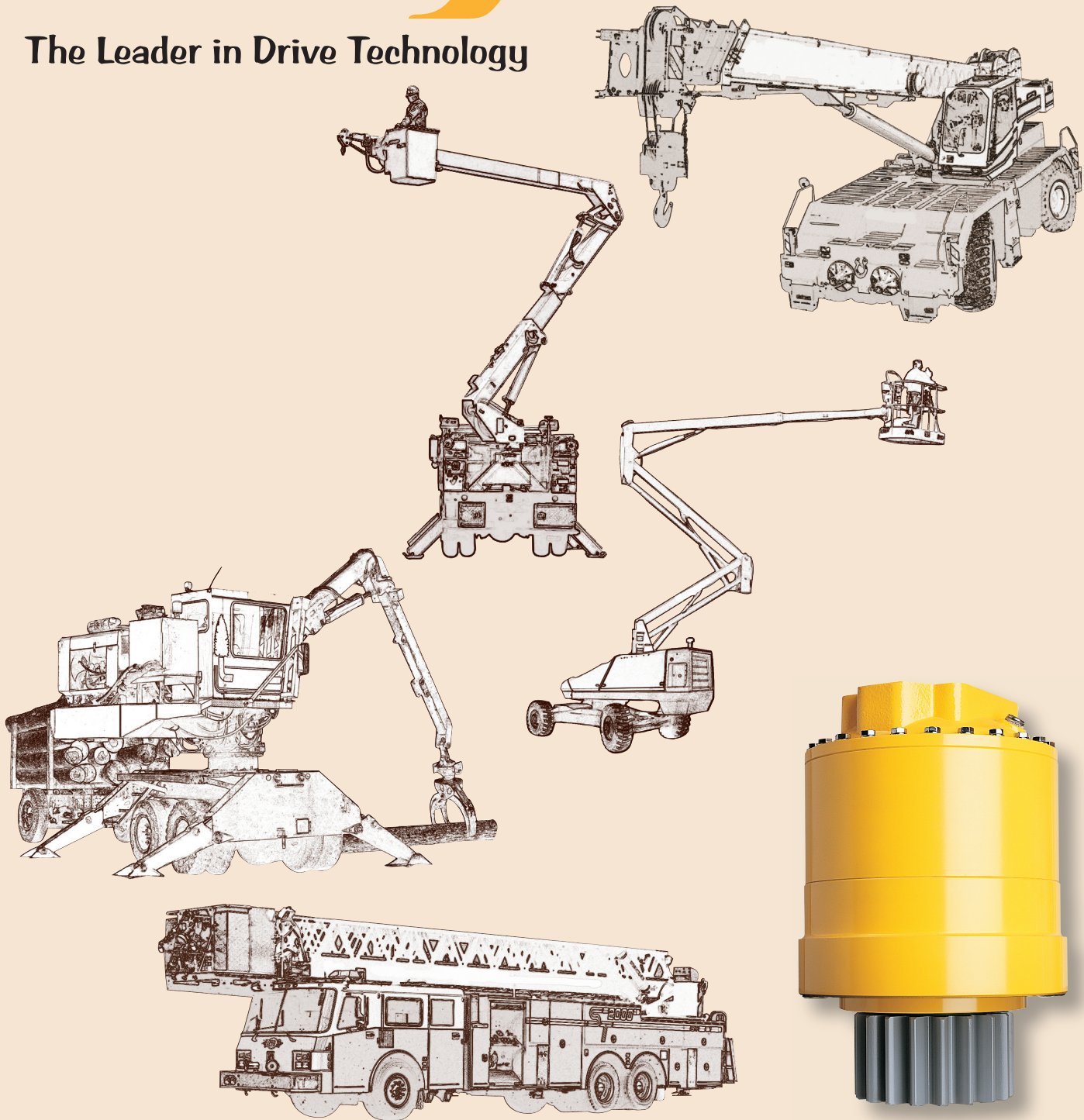

The Leader in Drive Technology



Power Wheel[®]

Planetary Gear Swing Drives



Auburn Gear has over 35 years of experience in manufacturing Power Wheel® planetary gear drives for mobile and stationary applications that are used on a wide array of equipment worldwide. With this long-term expertise, we have developed a reputation of producing the highest quality, most durable and reliable planetary gear drives in the industry. Auburn Gear is also committed to providing the utmost level of post-sale customer service and support.

Swing Drives are an important and integral segment of our Power Wheel® planetary gear drive product line. Our Swing Drive gearboxes are used on a variety of applications such as aerial work platforms, construction cranes, utility bucket booms, excavators, rack drives, grapples, fire trucks and forestry equipment. The standard Swing Drives utilize integral pinion gears with a bearing-nut shaft retention device to provide reliable shaft retention and precise bearing preload. All Swing Drives are also built with high capacity tapered roller bearings. We offer several Model sizes with a variety of pinion configurations and multiple hub/flange mounting configurations. Let Auburn Gear help you find the most reliable and economic solution to your Swing Drive needs.

SWING DRIVE MODELS & GENERAL SPECIFICATIONS					
Model No.	Max. Intermittent Output Torque,* (lb-in) / [Nm]		Ratio Range	Motor Mounts	Motor Input Splines
	Single Reduction	Double Reduction			
Model 40	(20,000) [2,260]	(40,000) [4,520]	4.08 to 68.01 :1	SAE A, B	13T - 16/32 1"-6B
Model 6B	(30,000) [3,390]	(50,000) [5,650]	3.75 to 33.79 :1	SAE A, B, C	13T - 16/32 14T - 12/24 1"-6B
Model 7	(35,000) [3,950]	(70,000) [7,910]	3.75 to 33.79 :1	SAE A, B, C	13T - 16/32 14T - 12/24 1"-6B
Model 8B	N/A	(100,000) [11,300]	15.39 to 50.00 :1	SAE A, B, C, D	13T - 16/32 14T - 12/24
Model 9	N/A	(130,000) [14,690]	15.39 to 50.00 :1	SAE A, B, C, D	13T - 16/32 14T - 12/24
Model 10B	N/A	(180,000) [20,340]	17.79 to 52.35 :1	SAE A, B, C	13T - 16/32 14T - 12/24

* Depending on duty cycle and nature of the application, a normal continuous output torque of 1/3 to 1/2 of the Max. Intermittent Torque should yield satisfactory Power Wheel life. Customer testing and application analysis is strongly recommended.

Note: Static brakes are available for most models. Contact Auburn Gear for details.

Note: Due to varying pinion gear and hub/flange configurations, contact Auburn Gear for maximum radial load.

Note: The data presented in this catalog is for general information and preliminary layout purposes only. Auburn Gear, through its policy of continual improvement, reserves the right to update its products; therefore, the information presented is subject to change. For specific application and/or dimensional information, contact Auburn Gear.

We offer a variety of frame-mounting Hub/Flange configurations in both gray iron and ductile iron, dependant on load and output torque requirements. The Hubs/Flanges are produced to exacting specifications to ensure ease of installation. If you do not find the Hub/Flange configuration to fit your frame, please contact us at (260) 925-3200 or from our website at www.powerwheeldrives.com.

Hub/Flange-to-Frame Mount Configurations

Model 40 Hub/Flange

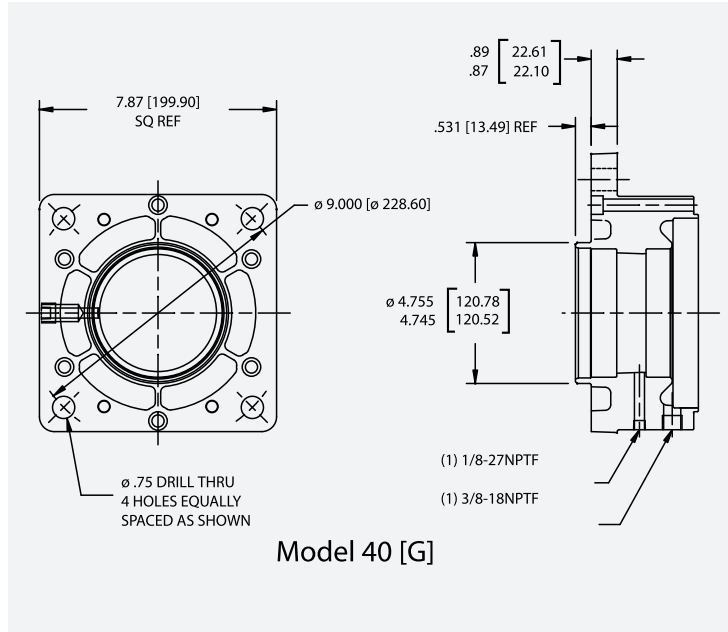
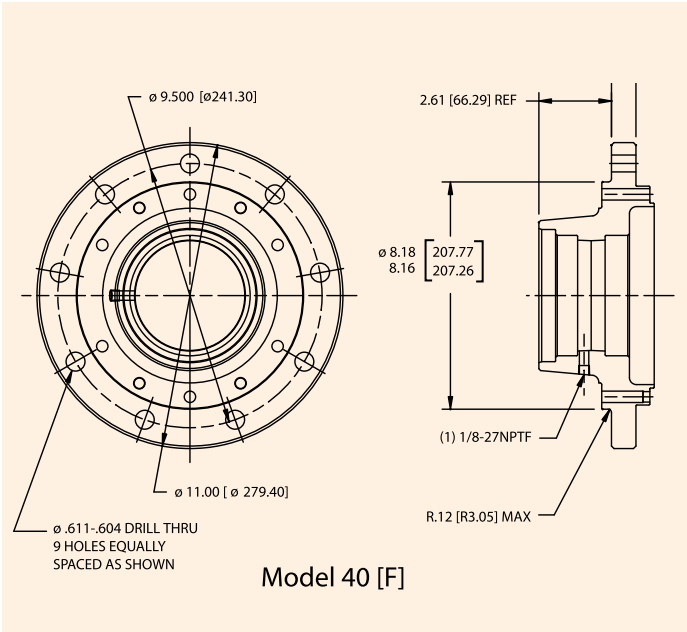

Model 6B & 7 Hub/Flange

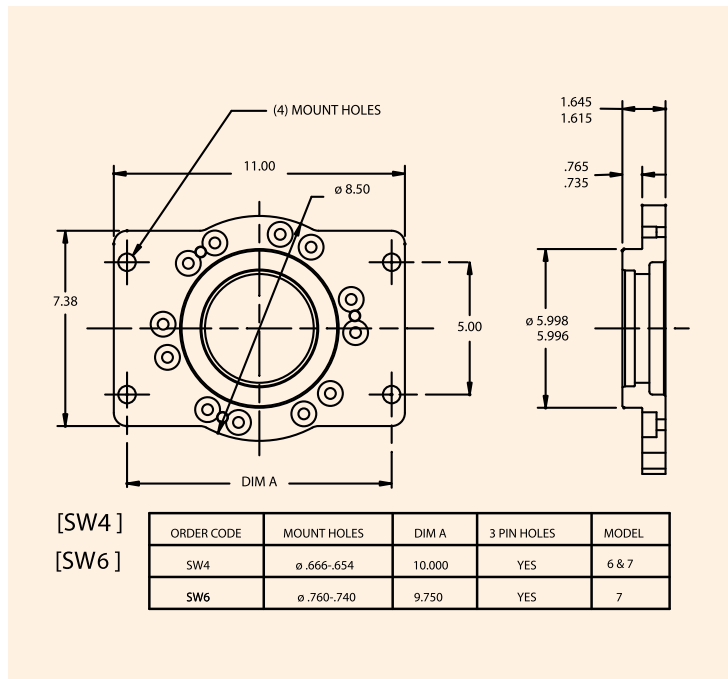
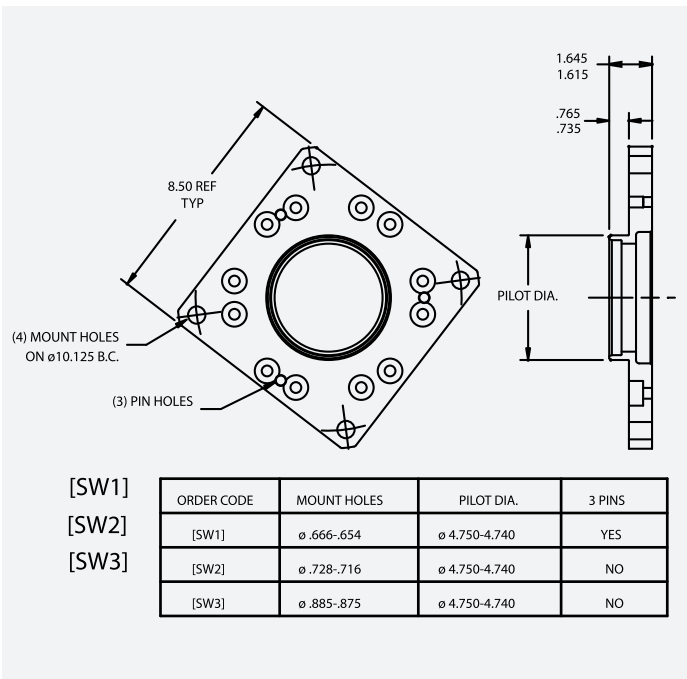

Model 6B & 7 Hub/Flange

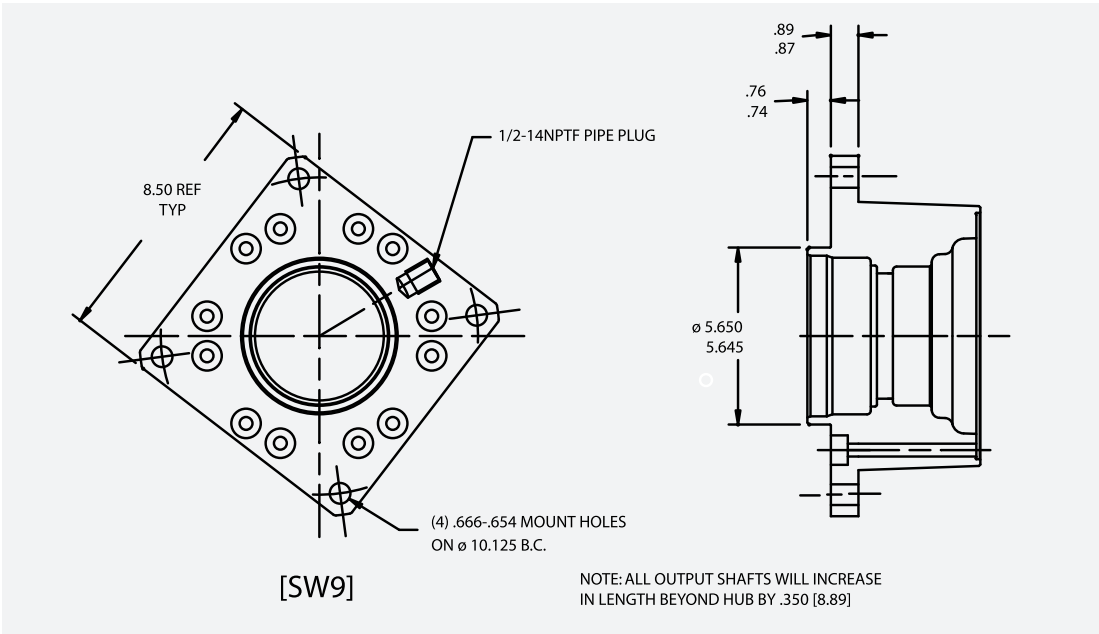
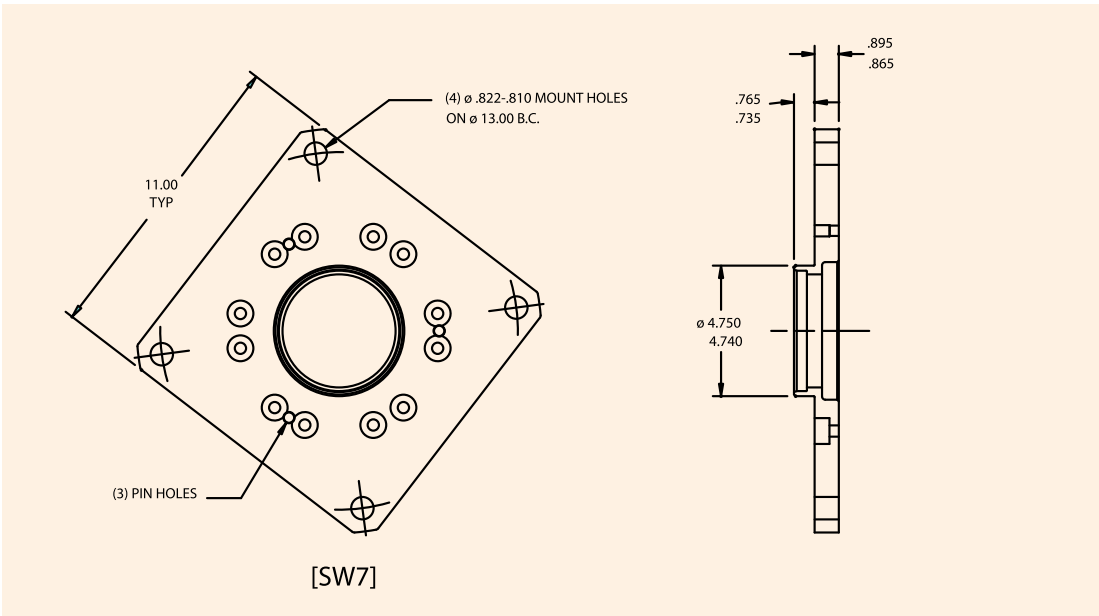
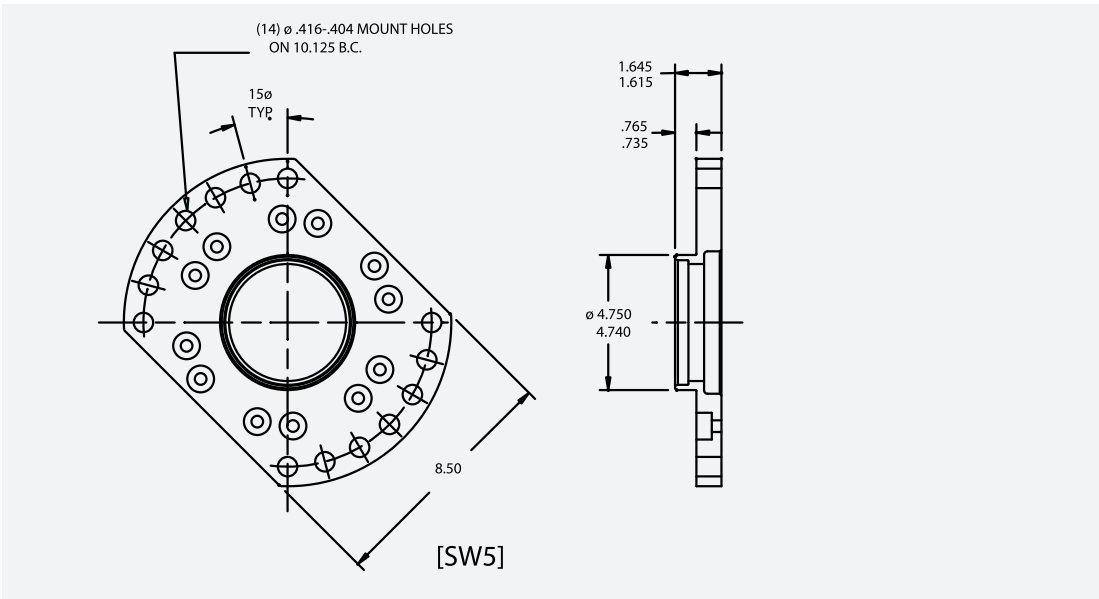

Note: The data presented in this catalog is for general information and preliminary layout purposes only. Auburn Gear, through its policy of continual improvement reserves the right to update its products; therefore, the information presented is subject to change. For specific application and/or dimensional information, contact Auburn Gear.

Model 8B & 9 Hub/Flange

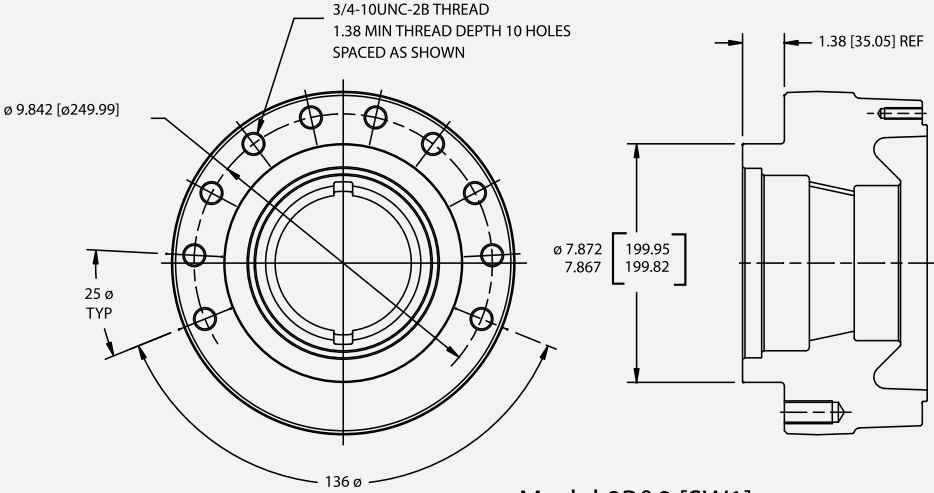

Model 8B&9 [SW1]

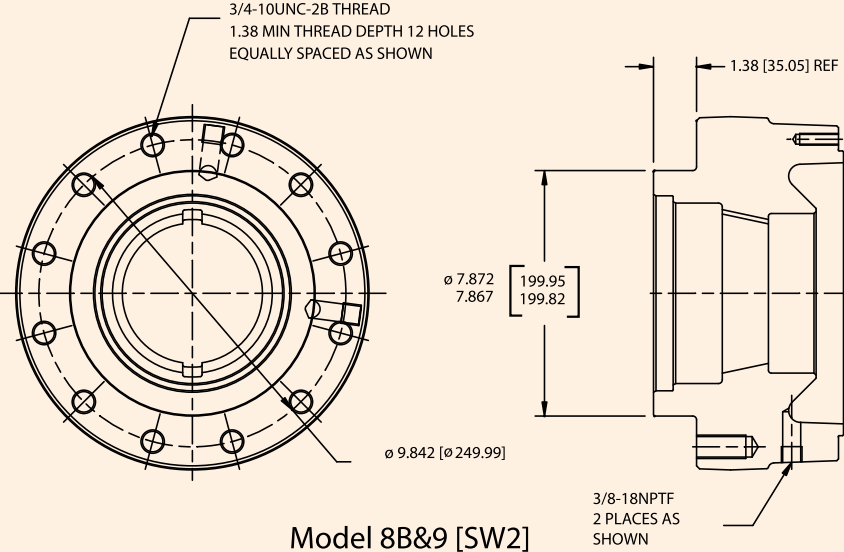

Model 8B&9 [SW2]

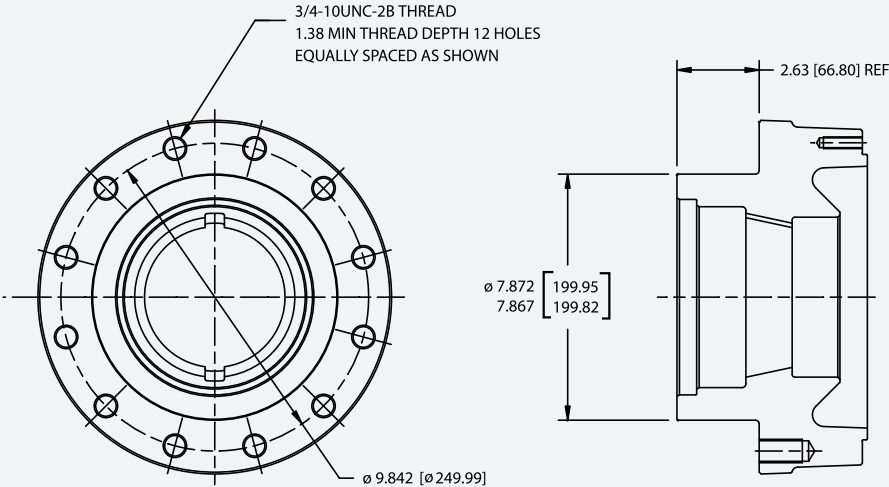

Model 8B&9 [SW3]

Model 8B & 9 Hub/Flange

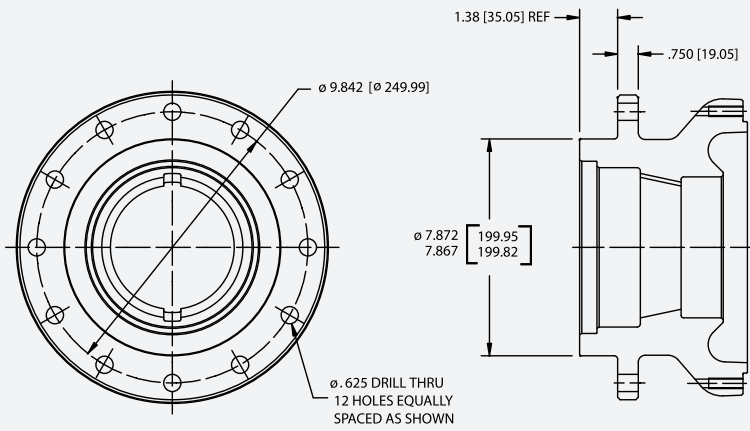

Model 8B&9 [SW5]

Model 8B&9
[SW6] WITH HUB SW2
[SW7] WITH HUB SW3

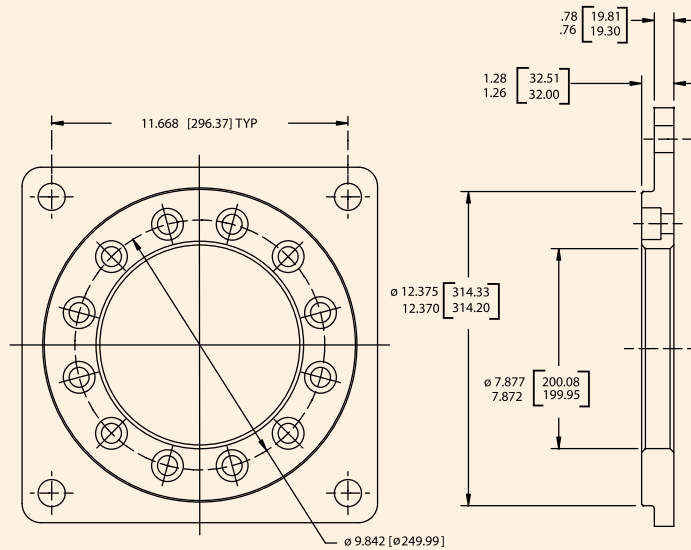

Model 10B Hub/Flange

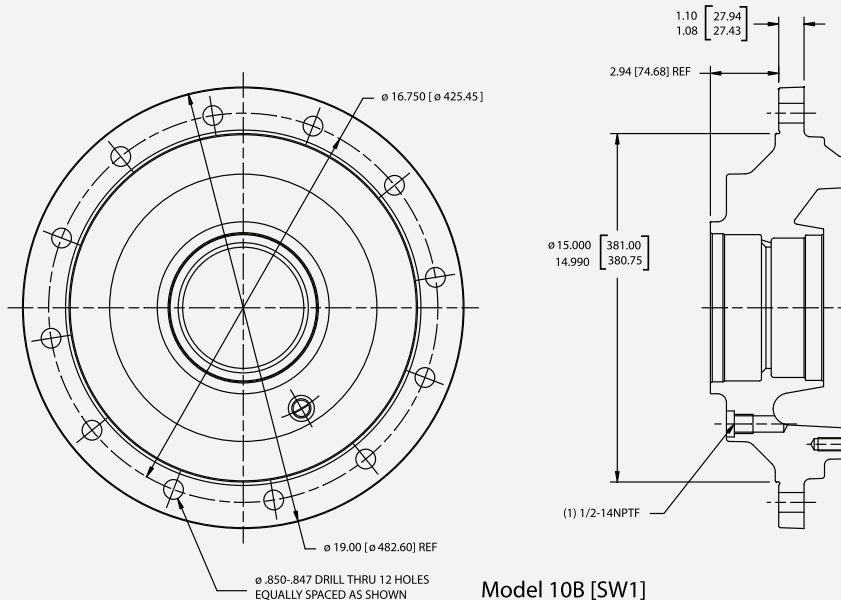

Model 10B [SW1]

Note: The data presented in this catalog is for general information and preliminary layout purposes only. Auburn Gear, through its policy of continual improvement reserves the right to update its products; therefore, the information presented is subject to change. For specific application and/or dimensional information, contact Auburn Gear.

Auburn Gear has developed a new design of Swing Drive mounts in the Models 8, 8B, and 9 sizes. The “Eccentric Mount” hubs are machined such that the mounting pilot and hub bolt circle are offset relative to the centerline of the output pinion gear. This offset relationship allows positioning of the pinion gear, relative to the rotation bearing, to be easily adjusted by simply rotating the gearbox.



Eccentric Mount Swing Drives

Model 8B & 9 Eccentric Mount

Features & Benefits:

- Eccentric mount built into the gearbox – no need to purchase adaptor rings.
- Permits initial backlash to the rotation bearing to be set more precisely.
- Allows a quick and easy method to adjust backlash as wear occurs.
- Can replace slotted bolt hole styles that have less precise adjustment capability.
- More economical maintenance and longer life.

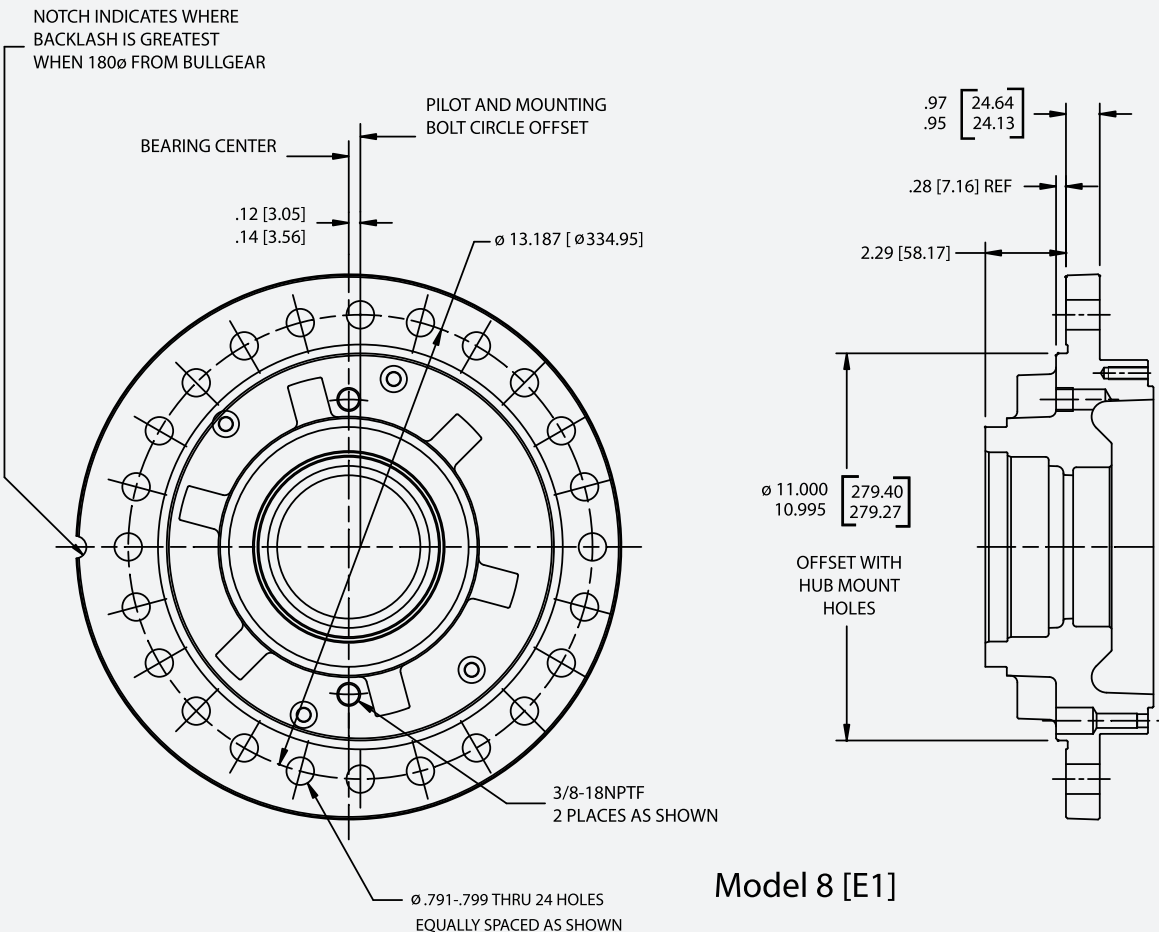

Model 8B & 9 Eccentric Mount

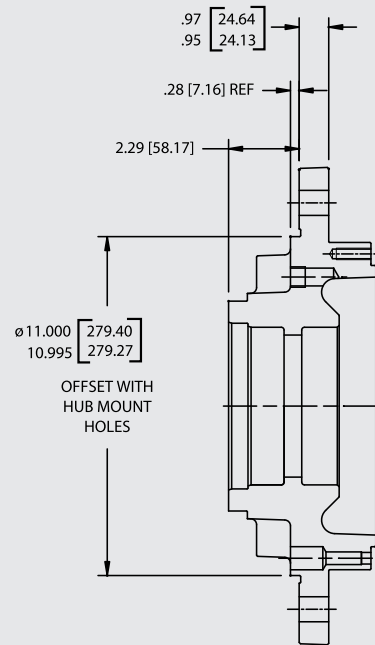
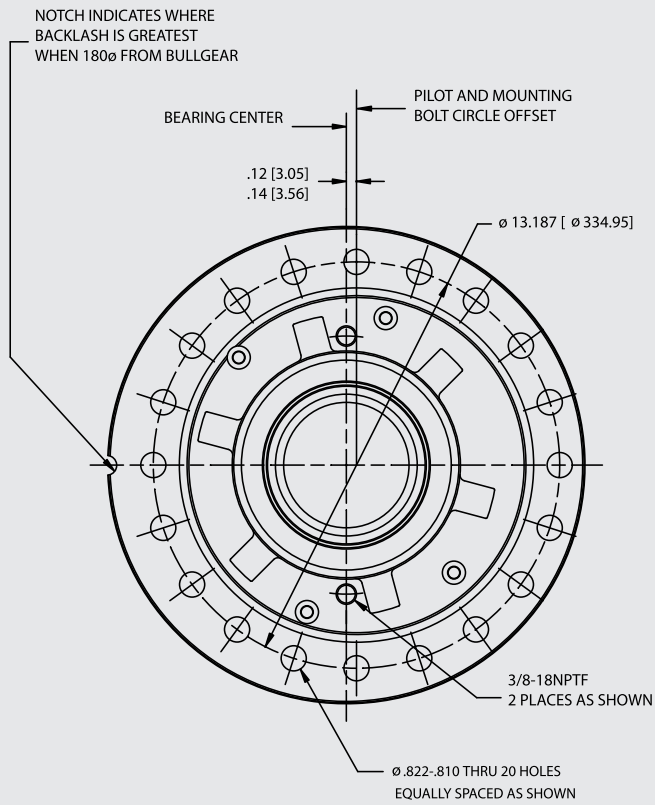

Model 8B [E2]

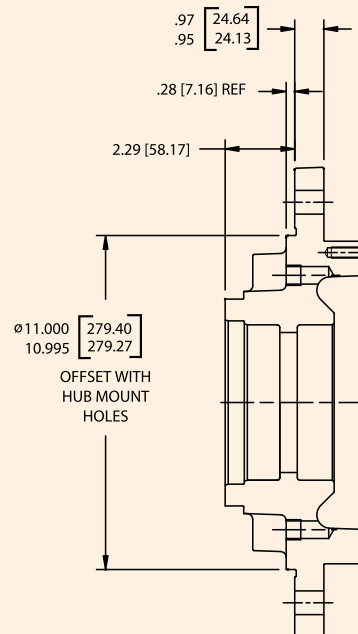
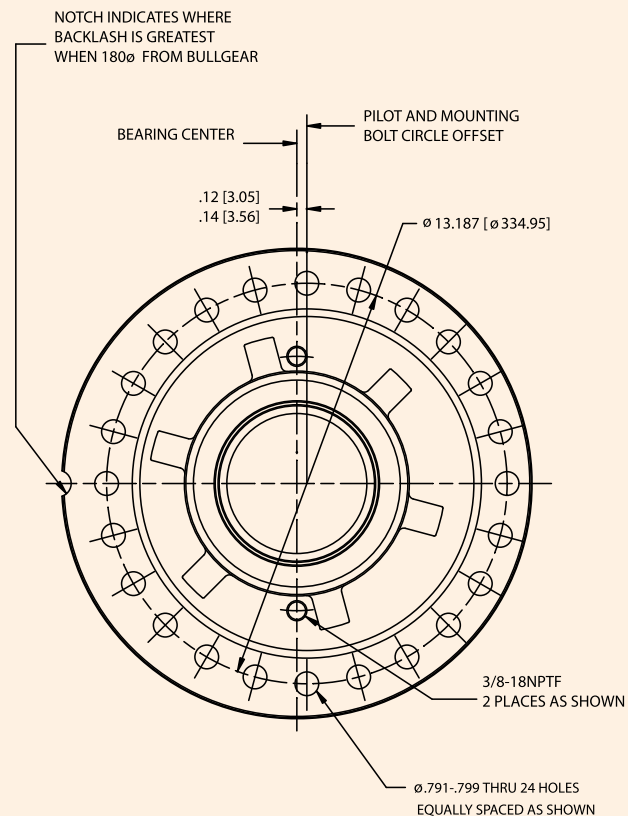

Model 9 [E1]

All output Pinion Gears are manufactured to AGMA standards and are produced using thru-hardened, high-alloy steel to attain the ultimate performance, strength and durability. We offer a wide range of gear tooth counts, pitches, and face widths. If you do not find the Pinion Gear configuration to match your rotation bearing, please contact us at (260) 925-3200 or from our website at www.powerwheeldrives.com.

Pinion Gear Configurations

Model 40 Pinion Gear

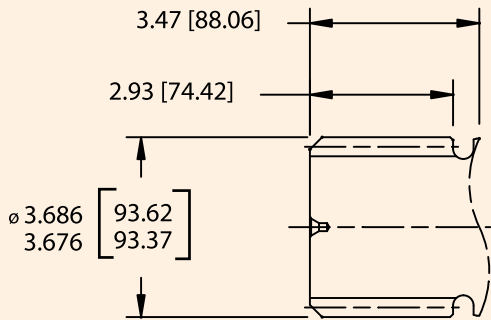

[G1]

PINION GEAR DATA

of Teeth = 17 * Diam. Pitch = 5/7
 Pressure Angle = 20 * Pitch Dia. = 3.40 (86.36)
 Minor Dia. = 2.90-2.89 (73.66)-(73.41)

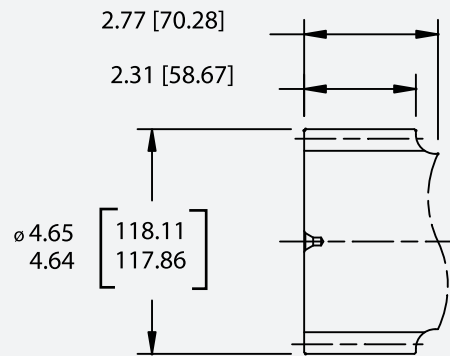

[G2]

PINION GEAR DATA

of Teeth = 17 * Diam. Pitch = 4/5
 Pressure Angle = 20 * Pitch Dia. = 4.25 (107.95)
 Minor Dia. = 3.75-3.74 (95.25)-(94.996)

Model 6B & 7 Pinion Gear

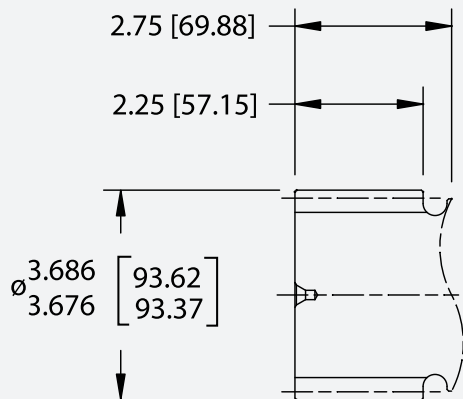

[G1]

PINION GEAR DATA

of Teeth = 17 * Diam. Pitch = 5/7
 Pressure Angle = 20 * Pitch Dia. = 3.40 (86.36)
 Minor Dia. = 2.90-2.89 (73.665)-(73.411)

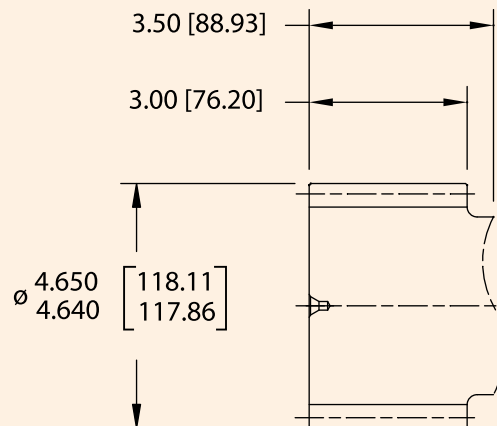

[G2]

PINION GEAR DATA

of Teeth = 17 * Diam. Pitch = 4/5
 Pressure Angle = 20 * Pitch Dia. = 4.25 (107.95)
 Minor Dia. = 3.74-3.75 (94.996)-(95.25)

Model 6B & 7 Pinion Gear

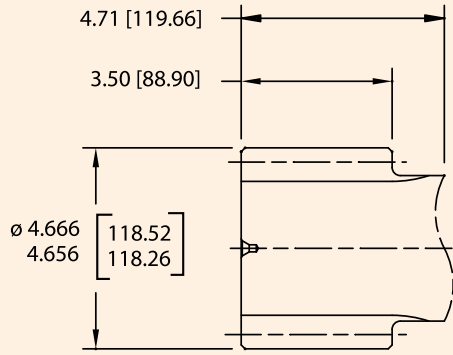

[G3]

PINION GEAR DATA

of Teeth = 12 * Diam. Pitch = 3
 Pressure Angle = 25 * Pitch Dia. = 4.00 (101.60)
 Minor Dia. = 3.105-3.095 (78.857)-(78.603)

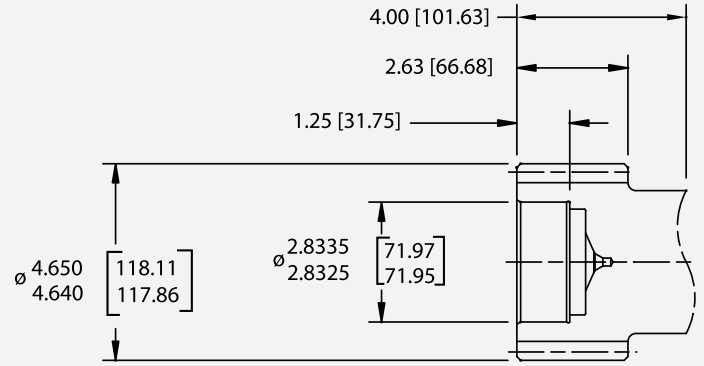

[G4]

PINION GEAR DATA

of Teeth = 17 * Diam. Pitch = 4/5
 Pressure Angle = 20 * Pitch Dia. = 4.25 (107.95)
 Minor Dia. = 3.74-3.75 (94.996)-(95.25)

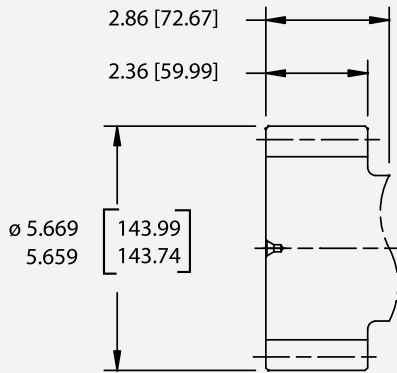

[G5]

PINION GEAR DATA

of Teeth = 16 * Diam. Pitch = 8 MODULE
 Pressure Angle = 20 * Pitch Dia. = 5.039 (127.99)
 Minor Dia. = 4.251-4.241 (107.97)-(107.72)

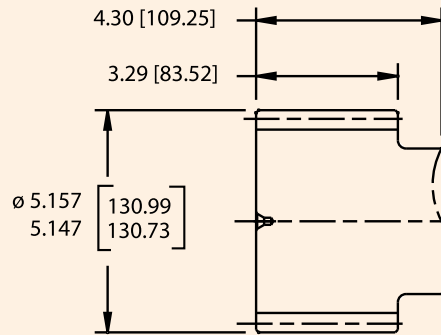

[G6]

PINION GEAR DATA

of Teeth = 19 * Diam. Pitch = 4/5
 Pressure Angle = 20 * Pitch Dia. = 4.75 (120.65)
 Minor Dia. = 4.26-4.25 (108.20)-(107.95)

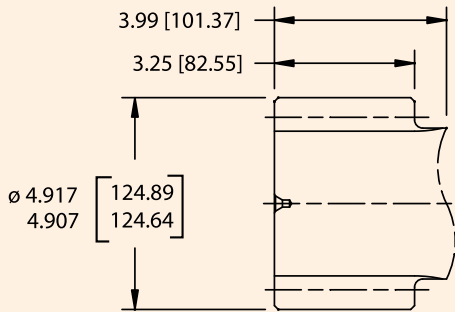

[G7]

PINION GEAR DATA

of Teeth = 12 * Diam. Pitch = 3
 Pressure Angle = 20 * Pitch Dia. = 4.00 (101.60)
 Minor Dia. = 3.351-3.341 (85.11)-(84.86)

Note: The data presented in this catalog is for general information and preliminary layout purposes only. Auburn Gear, through its policy of continual improvement reserves the right to update its products; therefore, the information presented is subject to change. For specific application and/or dimensional information, contact Auburn Gear.

Model 6B & 7 Pinion Gear

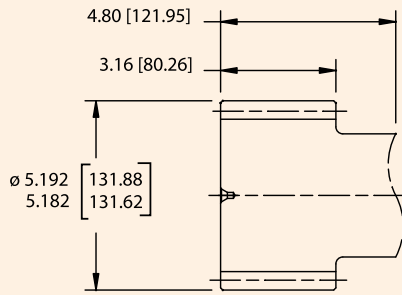

[G8]

PINION GEAR DATA

of Teeth = 19 * Diam. Pitch = 6 MODULE
 Pressure Angle = 20 * Pitch Dia. = 4.49 (114.05)
 Minor Dia. = 4.181-4.171 (106.20)-(105.94)

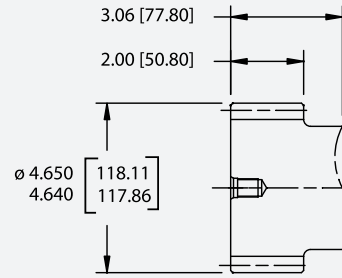

[G9]

PINION GEAR DATA

of Teeth = 17 * Diam. Pitch = 4/5
 Pressure Angle = 20 * Pitch Dia. = 4.25 (107.95)
 Minor Dia. = 3.74-3.75 (94.996)-(95.25)

Model 8B & 9 Pinion Gear

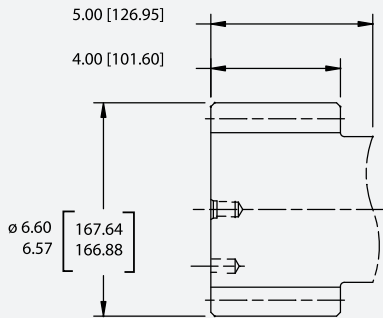

[G1]

PINION GEAR DATA

of Teeth = 14 * Diam. Pitch = 2.5
 Pressure Angle = 20 * Pitch Dia. = 5.60 (142.24)
 Minor Dia. = 4.764-4.734 (121.0)-(120.24)

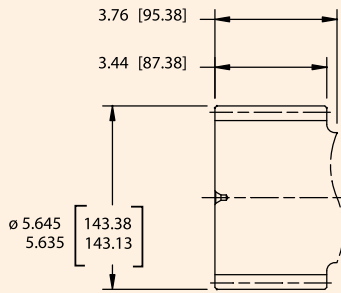

[G2]

PINION GEAR DATA

of Teeth = 21 * Diam. Pitch = 4/5
 Pressure Angle = 20 * Pitch Dia. = 5.25 (133.35)
 Minor Dia. = 4.745-4.725 (120.523)-(120.269)

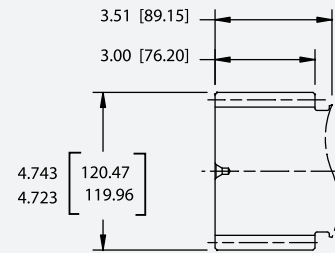

[G3]

PINION GEAR DATA

of Teeth = 15 * Diam. Pitch = 3.5 STUB
 Pressure Angle = 20 * Pitch Dia. = 4.286 (108.86)
 Minor Dia. = 3.7144-3.6944 (94.346)-(93.838)

Model 10B Pinion Gear

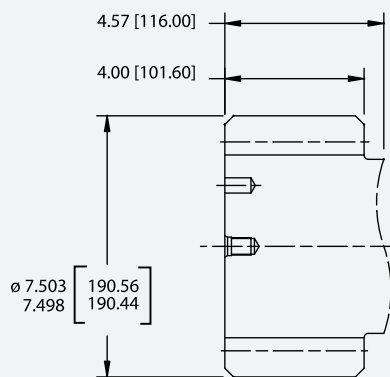

[G1]

PINION GEAR DATA

of Teeth = 12 * Diam. Pitch = 2.0
 Pressure Angle = 20 * Pitch Dia. = 6.00 (152.4)
 Minor Dia. = 5.253-5.248 (133.43)-(133.30)



400 East Auburn Drive
Auburn, Indiana 46706-3499 • USA
PH: (260) 925-3200
FAX: (260) 925-4725
E-mail: powerwheel@auburngear.com
Web: www.powerwheeldrives.com



Power Wheel[®]

Planetary Gear Swing Drives

PWSW-10/07-2000