

Power Wheel® Service Manual
Model 8 Single Reduction
Shaft and Spindle Output Drives
With Bearing Locknut Option

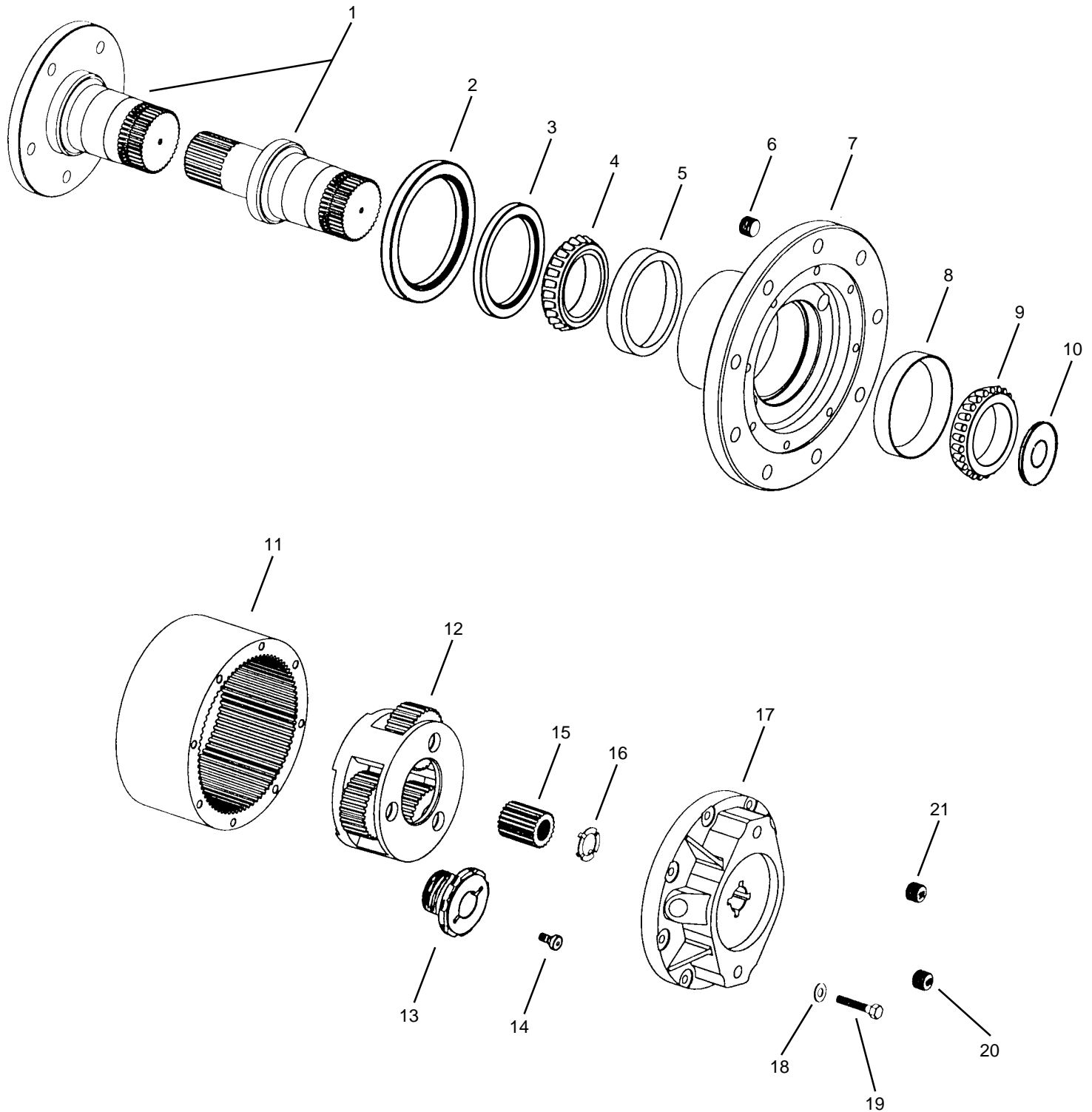

PHONE: (219) 925-3200
FAX: (219) 925-4725



IDENTIFICATION

IMPORTANT: All Power Wheel units and kits are shipped with a nameplate that includes the Auburn Gear part number and order code as shown.

Example:



In addition to the nameplate, Power Wheel drives are stamped with an identification number which appears on the cover or hub flange as shown.

Example: **6000236-A-4-9**

When ordering parts, the information included on the nameplate or the stamped identification number is necessary to accurately identify the drive and obtain the correct replacement parts. Once this information has been obtained, contact Auburn Gear for the appropriate parts list.

DISASSEMBLY OF POWER WHEEL

STEP 1

Remove twelve hex head bolts (19) and washers (18) from cover (17). Lift cover (17) from assembly. Thrust washer (16) usually remains with cover (17).

STEP 2

Lift sun gear (15) from carrier assembly (12).

STEP 3

Remove the carrier assembly (12). Removal is accomplished by loosening the lock screw (14) and bearing locknut (13) until the carrier assembly can be removed from the output shaft (1) splines. Loosen lock screw (14) with 3/16 hex drive. It may be necessary to remove the ring gear (11) first if difficulty is encountered in removing the carrier. **NOTE:** A special service tool is required for removal of the bearing locknut. Contact Auburn Gear for procurement of service tool.

STEP 4

Pull ring gear (11) from remaining assembly. It may be necessary to strike ring gear (11) with rubber mallet to loosen from hub (7).

STEP 5

Remove the large thrust washer (10) from in front of the tapered bearings and pull output shaft (1) from hub (7). If bearings are not a loose fit, it may be necessary to press output shaft (1) from hub (7).

STEP 6

Remove oil seal (3) and bearing cones (4 & 9) from hub (7). Inspect bearing cups (5 & 8) in hub (7) and remove only if replacement is required.

ASSEMBLY OF POWER WHEEL

STEP 1

Press bearing cups (5 & 8) into each side of hub (7). It is recommended that bearing cups (5 & 8) and cones (4 & 9) be replaced in sets.

STEP 2

Assemble bearing cone (4) into cup (5) at seal end of hub (7) and press a new seal (3) into hub (7). Install boot seal (2) on hub (7) if unit is so equipped.

STEP 3

Lubricate lips of seals (2 & 3) and lower hub (7) onto output shaft (1). Keep hub (7) centered to prevent damage to seals.

STEP 4

Assemble bearing cone (9) over output shaft (1) and into bearing cup (8). Replace large thrust washer (10) over output shaft (1) end splines and on bearing cone (9).

STEP 5

Assemble carrier assembly (12) splines over splined end of output shaft (1). Install bearing locknut (13). Tighten locknut to 50 lb. ft. (67.8Nm) while rotating the hub to seat the bearings. Loosen the locknut 1/2 turn then retighten locknut to 45 lb ft. (61.0 Nm) while rotating the hub. Loosen the locknut to nearest locking notch and secure with lockscrew (14). Tighten lockscrew (14) to 10 lb. ft. (13.6 Nm). Assembly must rotate freely with a preload of .003 in. (.08 mm) to an end play of .003 in. (.08 mm).

STEP 6

Clean mating surfaces and apply a bead of silicone sealant to face of hub (7) that mates with ring gear (11). See instructions on sealant package.

STEP 7

Assemble ring gear (11) to hub (7) being careful to align all the bolt holes.

STEP 8

Install sun gear (15) into carrier assembly. Sun gear (15) should turn freely by hand when assembled.

STEP 10

Apply a bead of silicone sealant to cover face of ring gear (11). Secure thrust washer (16) with tangs engaged in

cover (17). **NOTE:** Washer (16) can be secured to cover (17) with a small amount of grease or silicone sealant. Assemble cover (17) to ring gear (11). Align cover (17) with hub (7) such that pipe plug holes on cover align with mounting holes in hub.

STEP 11

Install twelve Grade 8 hex head bolts (19) and washers (18) and torque to 40 - 45 lb. ft. (54 - 61 Nm) with dry threads. Lubed threads torque to 20 - 25 lb. ft. (27 - 34 Nm).

STEP 12

Position filler opening horizontally and fill unit to oil level hole in hub (7). Install pipe plugs (6, 20 & 21).

NOTE: When installing a hydraulic motor to the Power Wheel drive it is necessary to place an "O" ring or gasket (not supplied by Auburn Gear) between the motor and the planetary drive. "O" ring sizes: SAE A 2-042, SAE B 2-155, SAE C 2-159, SAE D 2-163. Apply sealant to motor mounting bolt threads when holes in cover are thru holes.

CARRIER ASSEMBLIES

It is recommended that the carrier assembly (12) be serviced in its entirety to protect the integrity of the Power Wheel drive.

LUBRICATION RECOMMENDATIONS

IMPORTANT: POWER WHEEL PLANETARY DRIVES ARE SHIPPED WITHOUT LUBRICANT AND MUST BE FILLED TO THE PROPER LEVEL PRIOR TO START UP.

Observe lubrication recommendations given by the original equipment manufacturer. When specific recommendations are not available, use mild extreme pressure lubricant API-GL-5, No. 80 or 90 when filling the Power Wheel under normal temperature ranges between 0 - 120°F (-18 to 49°C). Power Wheel is to be half full of oil when unit is mounted level and horizontal. Use drain and fill plugs located in cover. Oil is to be changed after first 50 hours of operation with subsequent changes every 1000 hours or yearly, which ever comes first. If unit is to be operated vertically, if ambient conditions are outside the specified range, or if the oil temperature exceeds 200°F (93°C) contact Auburn Gear for oil and level recommendations.

STORAGE

A protective film is applied to the Power Wheel at the factory to prevent rust during shipment. Additional protection may be required if the Power Wheel is to be stored for an extended period of time.

SEALING COMPOUND

Silastic RTV732 sealer and General Electric Silimate RTV No. 1473 or RTV No. 1503 are recommended for sealing gasket surfaces. Sealant should be applied in a continuous bead, which should be centered on the surface to be sealed but should move to the inside of the hole at each bolt hole location. For service requirements order Auburn Gear part number 604101.

SPECIFICATIONS

Maximum intermittent output torque	60,000 lb. in. (6,780 Nm)
Maximum input speed	5,000 RPM
Oil capacity	38 oz (1,125ml)

ITEM NO.	DESCRIPTION*	NO. USED IN ASS'Y.	ITEM NO.	DESCRIPTION*	NO. USED IN ASS'Y.
1	Output Shaft or Spindle	1	12	Carrier Assembly	1
2	Boot Seal 604405	1	13	Locknut (serviced as part of the Carrier Assembly)	1
3	Oil Seal 14-00-044-011	1	14	Lock Screw 618304 (serviced as part of the Carrier Assembly)	1
4	Bearing Cone 14-00-133-007	1	15	Sun Gear	1
5	Bearing Cup 14-00-133-006	1	16	Thrust Washer	1
6	Pipe Plug 03-04-101-09	1-2	17	Cover	1
7	Hub	1	18	Flat Washer	12
8	Bearing Cup 14-00-133-008	1	19	Hex Head Bolt (Grade 8)	12
9	Bearing Cone 14-00-133-009	1	20	Pipe Plug 03-04-101-01	1
10	Thrust Washer	1	21	Magnetic Plug 14-00-052-002	1
11	Ring Gear	1			

* Contact Auburn Gear with part number and order code of drive to obtain the appropriate parts list. Refer to parts list for the specific part numbers and quantities.

Model 8 Power Wheel® Service Kits

Part No.	Description	Included Items
588x	Model 8 Bearing Locknut Tool	Not Shown